



AquaRev™
BY HDC PRODUCTS

Revolutionizing Water Treatment for a Better World

Mission and Vision

Our mission is to provide “Naturally Purified Water For the People and the Planet,” ensuring safer and higher-quality water availability while contributing to global sustainability.

Our vision is to become a global leader in the water treatment sector, known for our commitment to innovation, customer satisfaction, and environmental stewardship. We envision a world where water scarcity and quality are no longer concerns, and AquaRev™ solutions play a significant role in making this a reality.



The Problem: Water Scarcity, Pollution and Public Health

- **The world faces increasing water shortages** due to climate change, unsustainable usage, and inefficient water management. **High evaporation rates in residential, commercial, municipal and agricultural water bodies exacerbate this scarcity.** Moreover, the heavy reliance on chemicals and single-use plastics contribute to environmental pollution and health risks.
- **Lack of access to safe drinking water** is a daily reality in many areas, and rising contamination levels and water shortages right here in the U.S. are affecting millions of people and slowing economic growth and prosperity.
- An estimated **273.87 billion gallons of water are lost each year** from all the pools in the U.S. due to evaporation.
- **Over-chlorination and exposure to toxic chloramine gas** in recreational water bodies and drinking water is a public health risk that is not being addressed adequately.



The Solution: AquaRev™ Water Enhancement Technology

- **We offer an effective solution for water scarcity and pollution** with our patented and NSF certified hydrodynamic sanitation water conditioning systems. **Our unique technology has consistently proven to reduce evaporation by around 70%**, while greatly reducing the amount of chemicals needed for sanitation.
- **Our systems enhance water quality, safety and clarity** while drastically reducing the amount toxic ozone-depleting chloramine gas emissions .
- **We not only conserve water and reduce chemical needs, but also reduce energy consumption** contributing to healthier ecosystems and safer water supplies.



WHAT IS IT?

- HDC PRODUCTS offers the AquaRev™ device that optimizes water sanitation by harnessing Hydrodynamic Cavitation (HDC).
- Certified at IAPMO R&T LAB and proven to reduce the production of the toxic and carcinogenic gas (aka chloramine) released in and around pools/spas/water features doing substantial environmental damage.
- When the AquaRev Pool Device was NSF 50 certified via IAPMO R&T LAB, the test concluded that 41% less chlorine was needed to properly disinfect the test pool. IAPMO also showed 70% monthly reduction in evaporation-related water loss and naturally stabilized pH allowing for peak sanitation efficiency.
- Saves money, is Better for your health, Better for the environment, and increases customer satisfaction.



HOW IT WORKS

- Contaminated water enters the hydrodynamic cavitation (HDC) chamber
- Existing pressure pushes water through our patented chamber design creating a rapid drop in hydrostatic pressure (creating little to no back pressure).
- Imploding nanobubbles create a heat signature, breaking down bacteria, aggregating metals, and molecularly restructuring water.
- Conditioned water exits the chamber into your pool, spa, or plumbing.

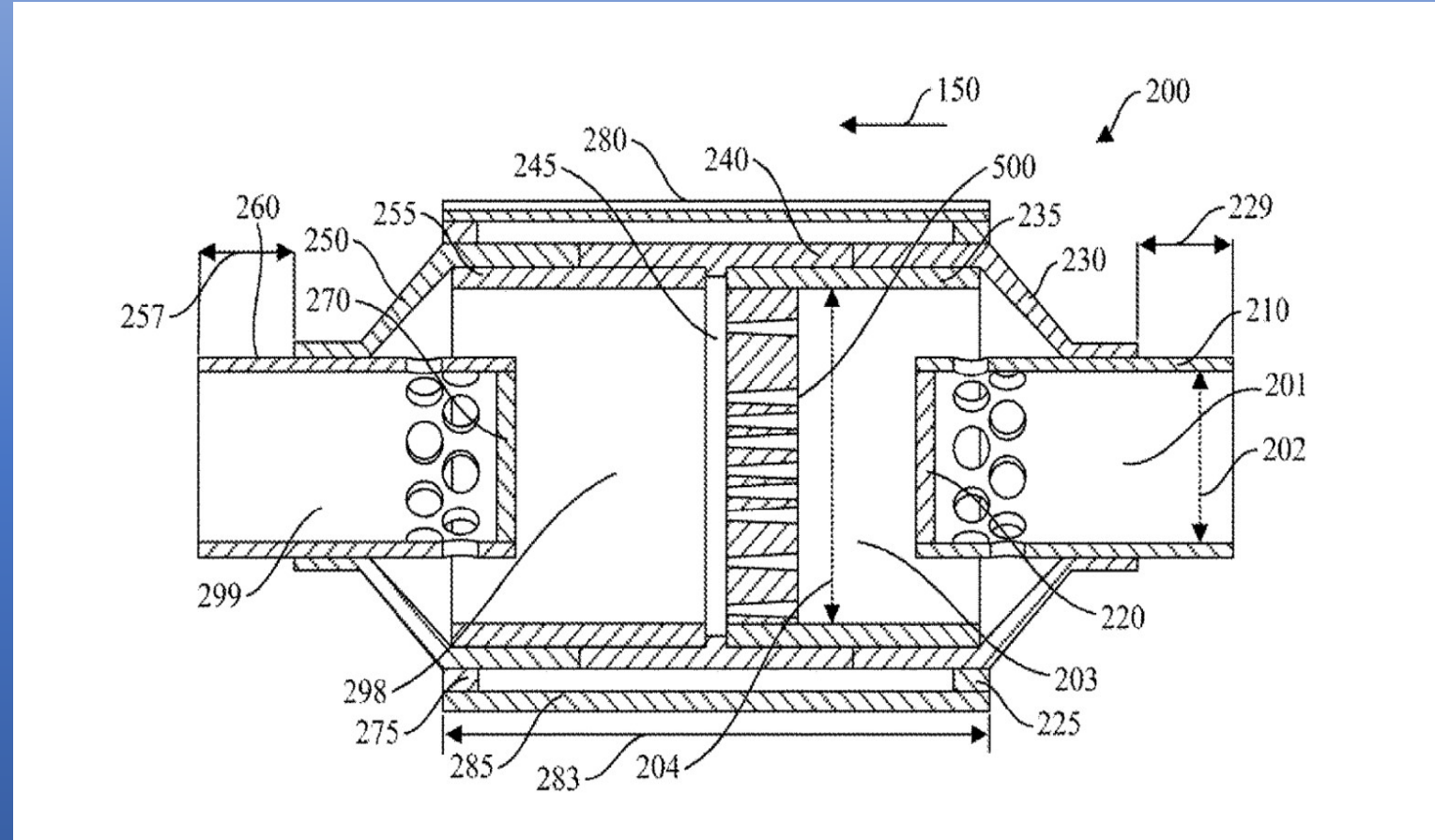

WHERE IT'S INSTALLED

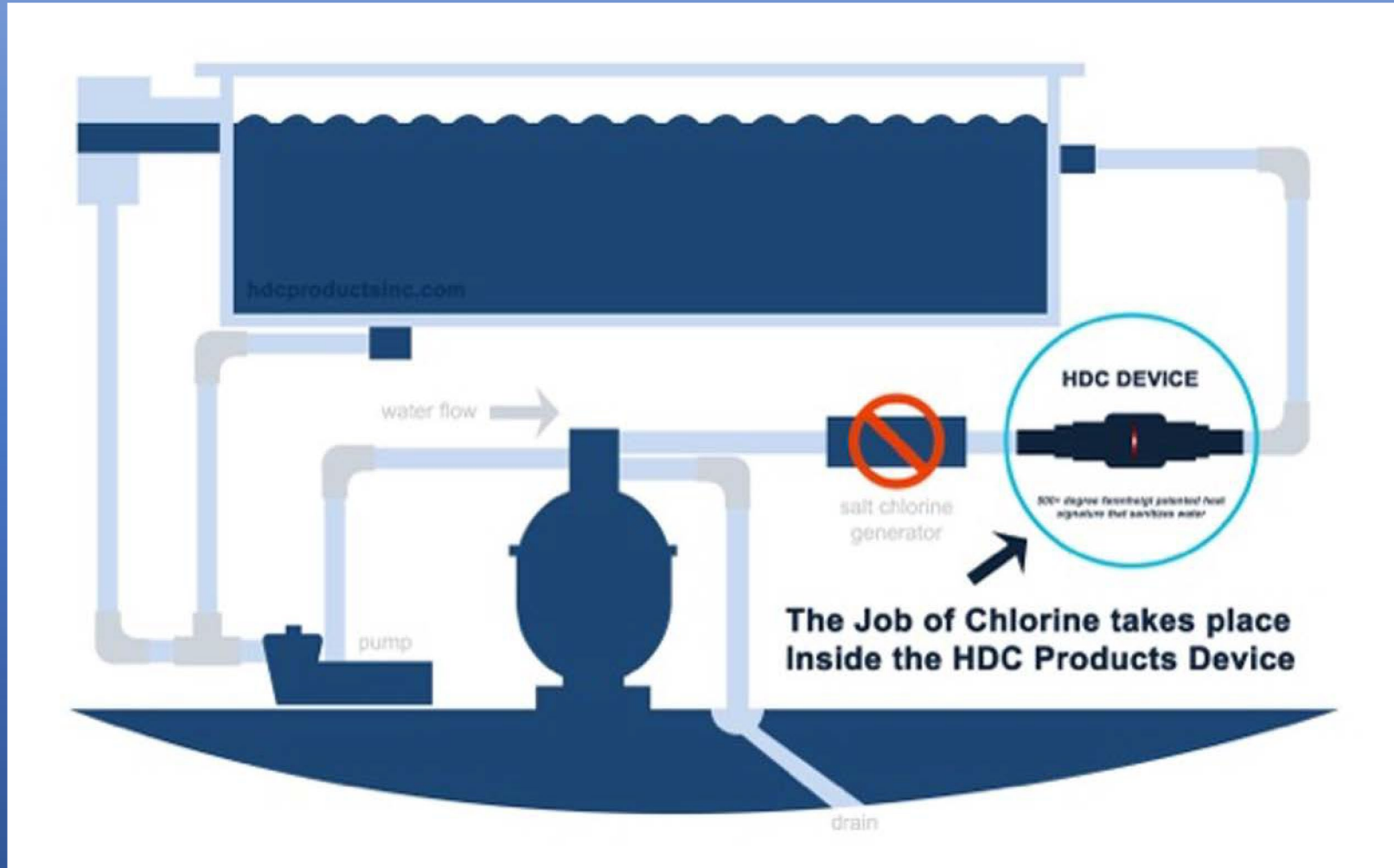

- AquaRev device should be installed last in line before water returns to the pool.
- In some cases, the Salt/Chlorine Generator can be removed but is usually left in line with the AquaRev System for a highly effective, healthier, and longer-lasting system.

Trusted by Leading Brands

NSF Certified, IAPMO R&T LAB Tested and Proven, Field Studied and Results Undeniable.

Our Customers Include:



Why Now?

Incredible Cost-Savings!

You could be saving \$1000's every year! Within just 6-24 months, you can expect your investment in AquaRev™ to pay for itself through significant savings on water, chemicals, salt, electricity, and equipment maintenance costs. For instance, Turtle Bay Resort transitioned to AquaRev™ receiving tremendous savings including nearly 68% in pool maintenance costs, and 10% on associated energy expenses *

*Used financial records comparing pre-install average yearly expenses to 2022 post-install year (before/after installation)

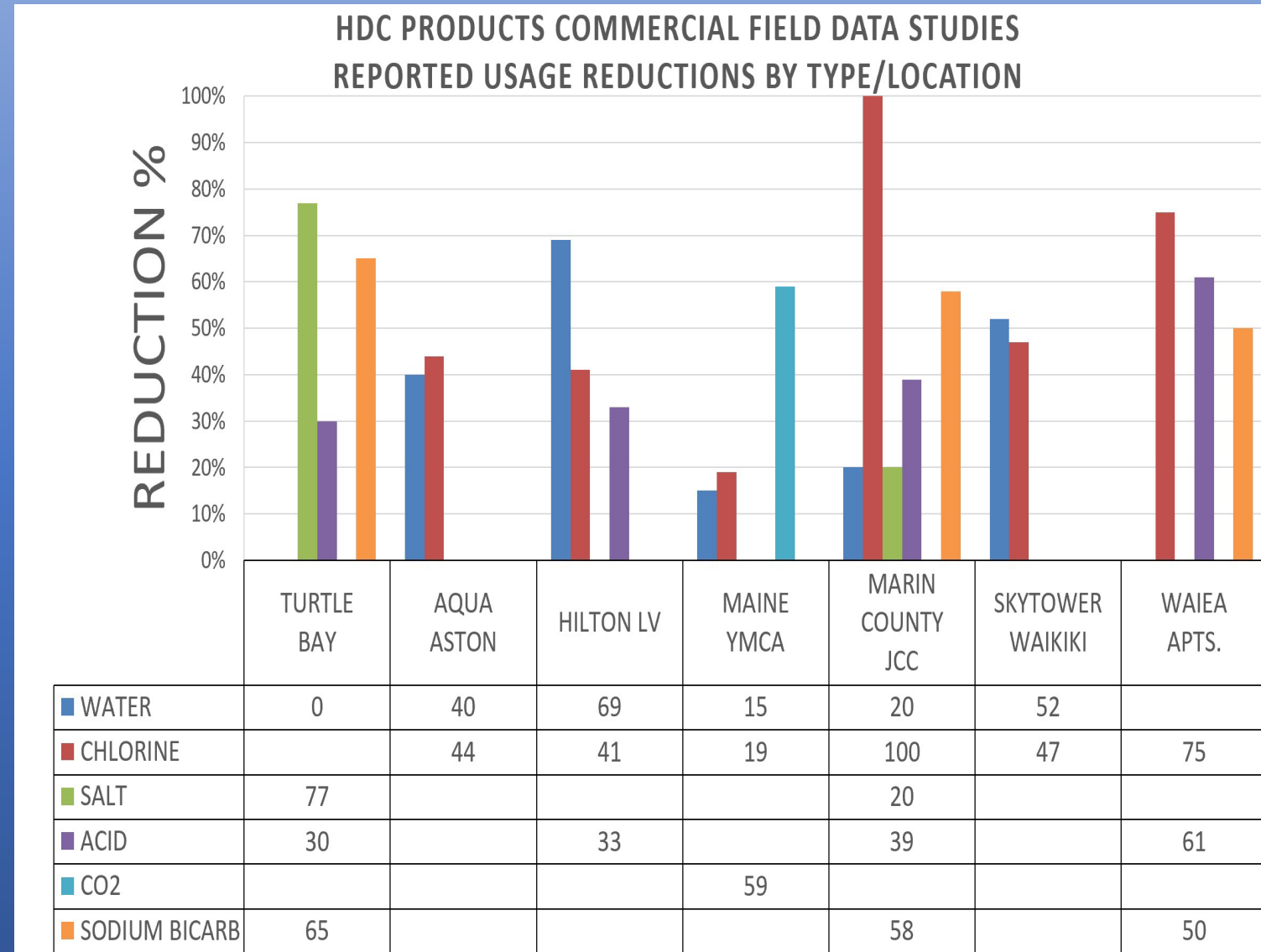

HDC PRODUCTS COMMERCIAL FIELD DATA STUDIES REPORTED USAGE REDUCTIONS BY TYPE/LOCATION

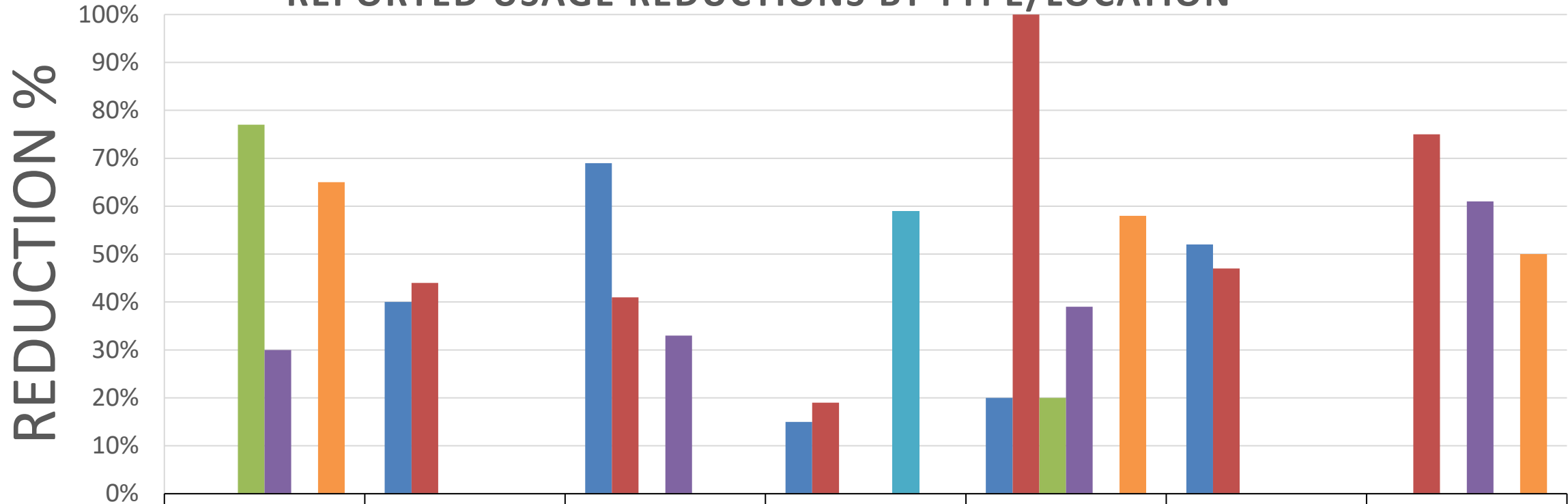

	TURTLE BAY	AQUA ASTON	HILTON LV	MAINE YMCA	MARIN COUNTY JCC	SKYTOWER WAIKIKI	WAIIEA APTS.
WATER	0	40	69	15	20	52	
CHLORINE		44	41	19	100	47	75
SALT	77				20		
ACID	30		33		39		61
CO2				59			
SODIUM BICARB	65				58		50

Sustainability

AquaRev™ provides a key component for “Pool Conservation” and Sustainability. By reducing the amount of water consumed by reducing the amount of water that naturally evaporates in all outdoor bodies of water, the amount of harmful by-products they produce, and the power required to keep them running safely.

BRE's 5-star Turtle Bay Resort is a prime example leading the way with its 2023 ESG report in which we are featured.



Pool Conservation

- ▶ All resort pools have been converted to use natural salt water rather than chemically based chlorine.
- ▶ The chlorine free HDC device naturally kills bacteria with a PH of 7.6 avg. It eliminates the need to manufacture, transport, store and use pool chlorine that is not as friendly to the environment, using high temperatures to sanitize the pools of contaminants.

 Since 2022, Turtle Bay has saved on all pool chemical usage, used 50% less sodium bicarb, 43% less Sulfuric Acid, 30% less salt, and has seen 60-70% less water evaporation.

ROI

- To help you calculate ROI, accurately record your baseline numbers including maintenance costs, chemicals added/cost, electric costs (pumps), and water added daily before installation.
- If you don't have a flow gauge and a water meter, you will want to either install these (good for monitoring pool condition or detect leaks) or speak with us about alternate means of recording use to ensure maximum benefits and accurate water savings calculations.
- The chemical savings alone will usually pay for the cost of the device in under ONE YEAR, and the maintenance, water and power savings are an added benefit.
- With less service/maintenance required across the board, you should be able to reduce labor expenses by 50% or more, providing more efficient use of your time on other things.
- In-house chemical cost savings and required supply store reduction will be significant, therefore supply chain disruption risks are mitigated.



Are Health Risks Being Ignored?

Over-chlorination and exposure to toxic chloramine gas in commercial/recreational water bodies and drinking water is documented public health risk by the CDC, which until now there has been no alternative to avoid.



Stop Damaging Your Body With Chloramines and Hard Water- Our Device Has Been Lab Tested to Reduce Chloramines by 36% and Iron by 99%!

It is well documented by the CDC that inhaling chloramines can lead to asthma and even permanent lung damage. Other issues from bathing in chlorine-rich environments include (but are not limited to): Ear, eye, nasal, and skin irritation & damage which can lead to hospitalization. If you can smell the chlorine around your pool, then you may be at risk from these toxic chloramines. Install The AquaRev™ today and live a healthier tomorrow.



HUGE BENEFITS

1. Reduces the Production of Toxic Carcinogenic Chloramines that are a byproduct of chlorine & salt based sanitation methods in the water and surrounding air (that "chlorine smell").
2. Enhances Water Clarity by Removing/Reducing Heavy Metals.
3. Naturally Balances pH (7.2-7.6).
4. Destroys Bacteria Naturally (allowing for a reduction in the use of chemicals)
5. Cleaner Facilities - Reduces hard water spots, calcium and iron stains/buildup in and around pool and spa areas and equipment.
6. Increases the ORP (Oxidative Reduction Potential) of the water allowing the water to defend itself naturally conserving salt & chemicals and reducing the amount needed.
7. Saves Water – Proven to reduce evaporation by up to 70% in outdoor pools!

The device has no moving parts and is installed on the return line requiring no maintenance.

Aqua Aston Testimonial:

"We had Kendal and the AquaRev/HDC team install their pool conditioning units in both our 1000 gal jacuzzi and our 60,000 gal pool. Both not only were costing us an immense amount of company resources, but causing constant headaches for our maintenance staff and required regular draining and large amounts of chlorine to maintain balance and clarity. I am pleased to say we have had spectacular results. Not only have we been able to save hundreds, sometimes thousands of gallons a week in water savings due to evaporation reduction and the fact we no longer have to constantly drain and refill the pools, but our chlorine & other chemical stabilizer costs were cut in HALF. Once installed, I was very pleased with their management's follow up efforts, walking us through all the break in procedures, and helping us address other apparent issues with our system, their knowledge and assistance saved us immense time and expense, and were provided at no additional cost. I highly recommend HDC Product's services and technology to every property manager in the country."

Jason Rego GM

The Outrigger Reef Waikiki Success Story

Installation Dec 2021

“Unbelievable water clarity, no chloramine smell, far less chlorine required and pH and other problems and guest complaints have gone away completely. Prior to the HDC device installations we were manually adding chlorine every few hours as needed to our spas and we not only stopped needing to do this, but also turned down the automatic chlorine injection system by roughly 33%. We’ve been able to cut our phosphate remover by over 50%. No longer need to drain the spas every 3-5 days since the HDC install and we are looking at 5 month or less ROI - unheard of in the industry.”

Albert Kahalehoe II - Director of
Engineering



SATISFACTION GUARANTEED



100% ROI within 1-2 years

* Based on savings in water loss to evaporation, electricity, chemicals, and maintenance

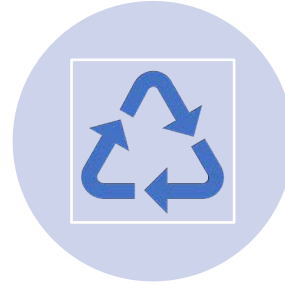

100% recyclable eco-friendly

Longevity – Made completely from high-quality, durable PVC that existing pool plumbing is composed of



10 Year non-prorated Warranty.

NSF-50/372 Certified via IAPMO R&T Labs



120 day 100% money back satisfaction guarantee.



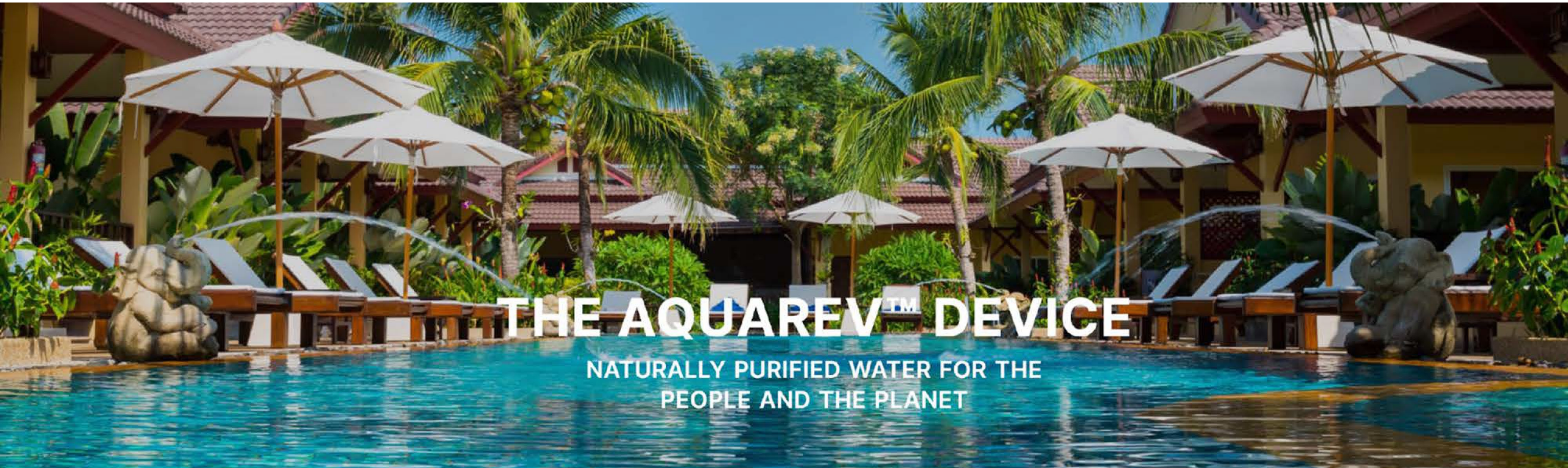

Kendal Vercoe | Operations Manager | 808-485-7108 | kendalv@hdcproductsinc.com

KD ENTERPRISES LLC | 4348 WAIALAE AVE 315 | HONOLULU, HI 96816 | AQUAREVWATER.COM